



AccuJet™ Electrostatic Spray System

The Model 102000 AccuJet Electrostatic Spray System improves chain lubrication while greatly reducing oil consumption and conveyor downtime. The patent-pending system consists of the following basic components:

- Dedicated control panel
- Up to four electrostatic spray nozzles with an injector pump for each nozzle
- 16 liter oil reservoir
- Pressure regulator/filter/pressure switch assembly

The electrostatic nozzles apply chain lube to the key lubrication points on the chain with extremely high transfer efficiency, saving oil, reducing chain breaks and limiting the downtime often associated with chain-driven conveyors. The system's low-flow injector pumps can deliver lubricant to as many as four electrostatic spray nozzles simultaneously. Pumps can be individually adjusted to deliver the precise volume of lubrication required to each spray station and can be easily added to the system after initial installation.

Benefits

- Completely uniform lubrication of critical areas between the pin and bushings extends chain life
- Eliminates oil mist and creates a safer work environment for operators
- Reduces the potential for product contamination from process lubricant
- High transfer efficiency reduces oil usage and operating costs
- Minimizes cleanup caused by overspray
- 100% pre-tested and pre-programmed for quick installation on site— no programming required

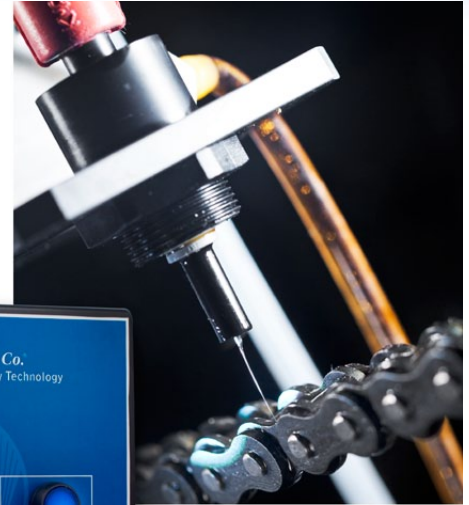

How Does Electrostatic Spray Coating Work?

Electrostatic spray technology is based on the scientific principle that “opposites attract.” In electrostatic spraying, a negatively charged liquid coating is attracted to a neutral, grounded target. This simple principle has powerful implications for advanced coating technology:

- The physical attraction of the liquid to the target pulls the coating to the chain surface, providing a very high transfer efficiency typically over 90%.
- Overspray is virtually eliminated, reducing clean-up and improving the work environment.

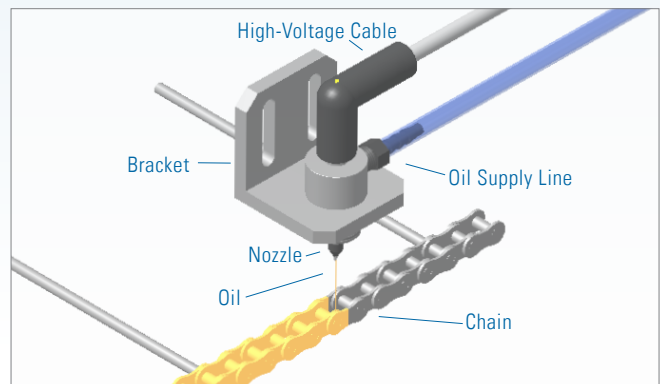

Typical Applications

Oil Coating

Chain Lubrication

Bearing and Roller Lubrication

Deco Pin Chain Lubrication

System Overview

- Electrostatic spray nozzles available with flow rates ranging from 0.3 – 5 cc/min each to accommodate different chain sizes and configurations
- Precision low-flow oil pumps provide individual flow control for each nozzle
- Standard system accommodates 1 - 4 pumps and spray nozzles. Custom system can accommodate up to 8 pumps and nozzles
- 16 liter reservoir includes built-in strainer and oil level switch
- Low oil level, low air pressure, and high-voltage fault detection circuits
- Automatic high voltage shutoff in the event of arcing
- Quick-disconnect high voltage cables and liquid fittings
- Relatively low operating voltage (less than 30 kV) with extremely low amperage (less than 1.5mA)
- Air Requirements – 60 psi (4 bar) minimum
- Power requirements - 24VDC 2.5A
- cTUVus control panel and CE compliant

Dimensions

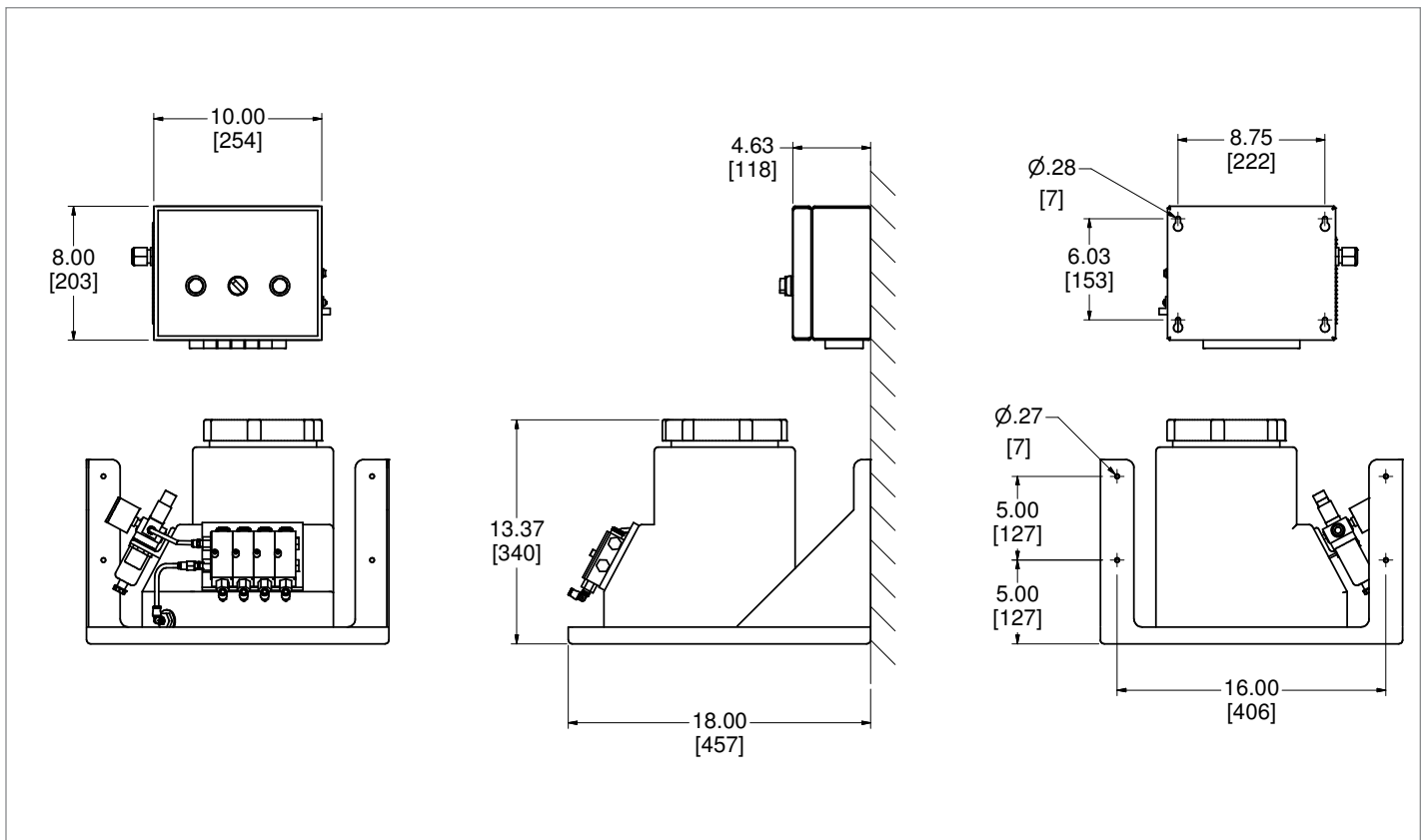

Spraying Systems Co.
Experts in Spray Technology

North Avenue and Schmale Road, P.O. Box 7900, Wheaton, IL 60187-7901 USA

Tel: 1.800.95.SPRAY Intl. Tel: 1.630.665.5000

Fax: 1.888.95.SPRAY Intl. Fax: 1.630.260.0842

www.spray.com



Spray
Nozzles



Spray
Control



Spray
Analysis



Spray
Fabrication

